

PART NUMBER	THREAD		A	B	C	H	V	W
			MAX	MIN	MIN	MAX	MIN	h12
HM41-030	M3	0,50	6,0	4,9	4,38	3,0	0,5	4
HM41-040	M4	0,70	8,0	6,5	5,51	4,0	0,6	5
HM41-050	M5	0,80	9,2	8,0	6,64	5,0	0,6	6
HM41-060	M6	1,00	10,5	9,4	7,74	5,4	0,9	7
HM41-070	M7	1,00	12,6	11,3	8,90	6,2	1,0	8
HM41-080	M8	1,25	13,6	12,3	11,05	7,0	1,1	10
HM41-080F	M8	1,00	13,6	12,3	11,05	7,0	1,1	10
HM41-100	M10	1,50	16,6	15,2	13,25	8,5	1,3	12
HM41-100F	M10	1,25	16,6	15,2	13,25	8,5	1,3	12
HM41-120	M12	1,50	19,8	18,7	15,51	10,5	2,0	14
HM41-120F	M12	1,25	19,8	18,7	15,51	10,5	2,0	14

MATERIAL: A286 corrosion resistant steel, composition per AMS 5732 or AMS 5735 (UNS 66286).

FINISH: HM41: Silver plate per AMS 2411
HM42: Kaylube molybdenum disulfide dry film lubricant per MIL-L-46010 + green dye.

THREAD DATA: Thread Profile: ISO 5855/1 and to MJ minor dia.
Tolerances: ISO 5855/2. Class 4H5H.

PERFORMANCE: AECMA 2053 (Tensile strength based on 1100 MPa).

TEMPERATURE: HM41: 425°C. HM42: 235°C.

DIMENSIONS: NFL 22541. LN 9161.

NOTE: 1. "C" and "W" dimensions apply before forming self-locking features.
2. Dimensions per NFL 22541, LN 9338, AECMA 2710.

HM41
HM42

SIX POINT NUT
CRES, METRIC

HM41
HM42

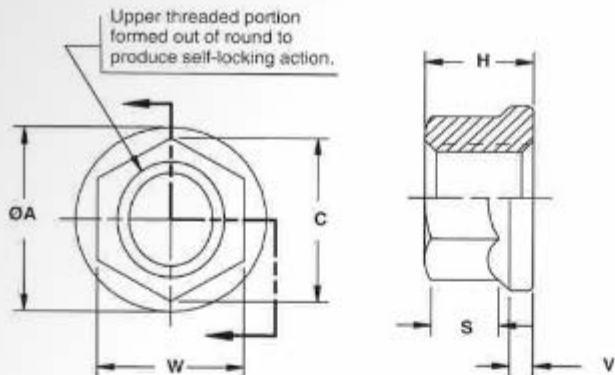

PART NUMBER	THREAD (MIL-S-8879)	A MAX	C MIN	H MAX	S MIN	V REF	W	APPROX WT LBS/100
H41-06	.1380-32 UNJC-3B	.244	.171	.141	.055	.032	.158-.150	.05
H41-08	.1640-32 UNJC-3B	.290	.207	.170	.060	.035	.190-.181	.09
H41M3	.1900-32 UNJF-3B	.330	.244	.188	.065	.035	.221-.213	.13
H41-3	.1900-32 UNJF-3B	.330	.277	.188	.065	.035	.252-.243	.18
H41M4	.2500-28 UNJF-3B	.420	.313	.219	.090	.045	.284-.274	.24
H41-4	.2500-28 UNJF-3B	.420	.347	.219	.090	.045	.316-.304	.30
H41-5	.3125-24 UNJF-3B	.520	.419	.266	.120	.050	.378-.367	.55
H41-6	.3750-24 UNJF-3B	.620	.491	.282	.125	.060	.440-.430	.76
H41-7	.4375-20 UNJF-3B	.720	.562	.328	.150	.070	.505-.494	1.26
H41-8	.5000-20 UNJF-3B	.820	.633	.480	.220	.080	.566-.555	2.07
H41-9	.5625-18 UNJF-3B	.922	.775	.540	.240	.090	.692-.680	3.26
H41-10	.6250-18 UNJF-3B	1.027	.846	.600	.250	.105	.755-.743	4.15

MATERIAL: A286 corrosion resistant steel per AMS 5732 or AMS 5737 (UNS S66286).

FINISH: Silver plate per AMS 2410.

PERFORMANCE: MIL-N-25027.

NOTES: "C" and "W" dimensions apply before forming self-locking feature.

H41

SIX POINT NUT
CRES STEEL, REDUCE HEIGHT

H41